



TIZIANO PROFESSIONAL has been developed with a stunning Italian design which makes it the ideal solution for high-end installations both for residential and professional environments.

If you are looking for a **refined Italian design** and excellent reliability the TIZIANO is the perfect solution. Extremely easy install, invisible mounting brackets and power cable are essential features of this exclusive product.

The aluminium housing has been designed with elegance in mind and is available in a wide range of different colours, enabling you to customise the finished screen to meet your customers' requirements.

Available in 1:1, 4:3 and 16:10 formats or bespoke sizes.

RAL housing colours
(optional)

- 9005
- 3000
- 9006
- 8017
- 5003
- 6029
- 1021
- Dark grey stone
- Light grey stone

Led lights for the housing
Available colours: white, blue, green, red
(optional)



Ceiling mounting brackets

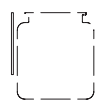

Wall mounting brackets



n.1 On/off switcher



RF Remote control with receiver built-in motor



Kit RF Remote control with external receiver



Interface switch 12 volt



Low voltage contact interface



Faster and quiet motor

INCLUDED

OPTIONAL pag 62-63

WALL MOUNTING BRACKET

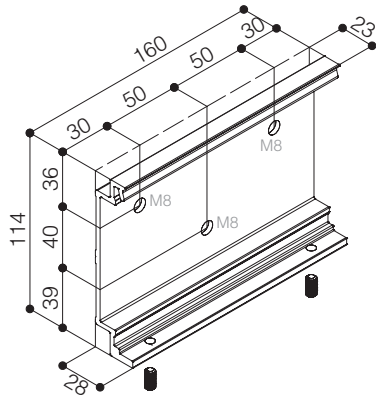

WALL MOUNTING

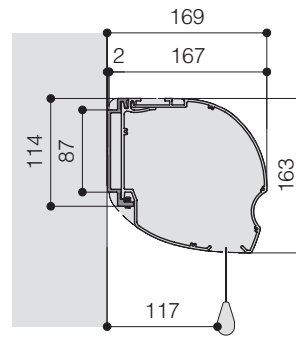

CEILING MOUNTING BRACKET

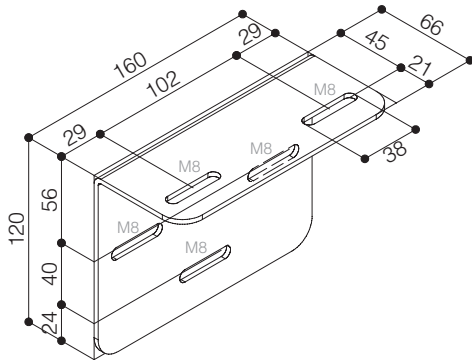

CEILING MOUNTING

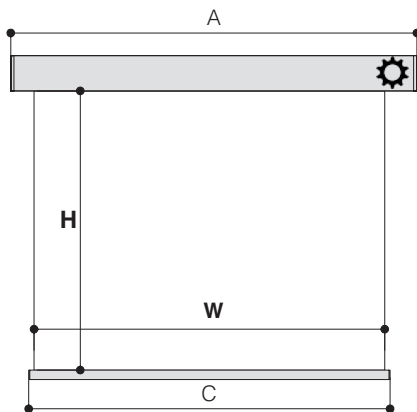
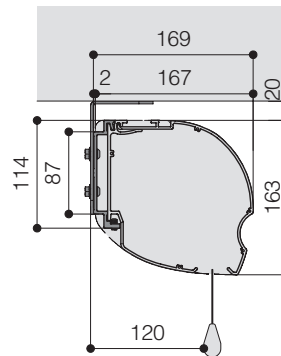

TECHNICAL SPECIFICATIONS

- Silent motor system provides a smooth and quiet operation
 - Power: **10 Nm**
 - Speed: **17 rpm**
 - Power supply: **230V / 50 Hz**
 - Consumption: **156 W**
 - Certification: **IMQ**
- Totally manufactured with aluminium housing and steel side plates
- Housing dimensions: 167x163 mm. (DxH)
- Housing painted with white epoxy powders (RAL 9016)
- White dowel bar: height 35 mm. - depth 20 mm.
- Wall mounting brackets and switcher on/off included
- Ceiling mounting brackets included
- Flame - retardant projection surfaces - classification M1, M2 and B1
- Cloth drops on the front side of the housing at 12,5 cm. from the wall
- Side black borders of 5 cm. and black dowel bar (optional)
- Screen housing available in different colours (optional)

The measures in the drawings are expressed in millimetres.

DIMENSIONS measures in cm

1:1 Ratio Viewing area (WxH)	4:3 Ratio Viewing area (WxH)	16:10 Ratio Viewing area (WxH)	Overall dimensions A - C	Approx. net weight (Kg)
160 x 160	160 x 120	160 x 100	171 - 164	18
180 x 180	180 x 135	180 x 112	191 - 184	20
200 x 200	200 x 150	200 x 125	211 - 204	21
220 x 220	220 x 165	220 x 137	231 - 224	23
250 x 250	250 x 190	250 x 156	261 - 254	25
300 x 300	300 x 225	300 x 187	311 - 304	29
350 x 350	350 x 265	350 x 219	361 - 354	33
400 x 400	400 x 300	400 x 250	411 - 404	37

PROJECTION CLOTHS

Front projection surfaces	Gain	Rear projection surfaces <i>**no black borders**</i>	Gain
White	1.2	Rear Plus	1.1
Matte White	1.2	Front Rear	0.9
Microperforated	1.1		
Lumi Grey Microperforated	0.8		
Ultra HD	1.2		

Warranty: 5 years on the motor - 24 months on the other components

