



PTO for technical specifications

## ScreenLabs “F” Type Electric

F Type Electric screen is a budget electric screen with fiberglass matt white surface and a tubular motor with limit switches, housed in a white shaped steel case. Channel fix – sliding brackets with quick attach fixing assist easy fixed to the wall or ceiling. With 3 cm black borders to all sides (4 cm on 244 cm width and above screens). There are 25 cm additional black leader on 16/9 and 16/10 formats.

### Technical specifications

- Available in Square (1:1), Video (4:3) and Widescreen (16:9) format
- Durable square-shaped steel housing with powder coated
- Universal mounting bracket with endcap making installation easy whether it is mounted on a wall, suspended or recessed above the ceiling
- Surface choices are Matt White, Glass Beaded and Pearlux White and Grey
- High Quality and economical choice
- 3cm Black borders to all sides, 4 cm on 244 cm wide screens
- 25 cm additional Black leader on 16/9 and 16/10 formats
- Supplied with IR control unit

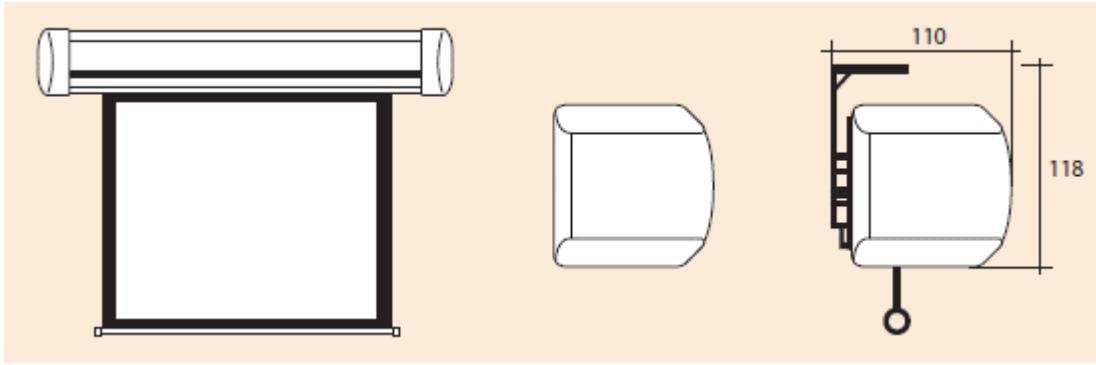

| Part Number | Format | Diag inc | Viewing Size cm | Overall size cm | Black Border(CM) |   |   |   |
|-------------|--------|----------|-----------------|-----------------|------------------|---|---|---|
|             |        |          |                 |                 | T                | B | L | R |
| 5084D       | 4:3    | 84       | 171 x 128       | 177 x 134       | 3                | 3 | 3 | 3 |
| 50100D      | 4:3    | 100      | 203 x 152       | 209 x 158       | 3                | 3 | 3 | 3 |
| 50120D      | 4:3    | 120      | 244 x 183       | 252 x 191       | 4                | 4 | 4 | 4 |
| 50150D      | 4:3    | 150      | 305 x 229       | 313 x 237       | 4                | 4 | 4 | 4 |
| 5077D       | 16:9   | 77       | 171 x 96        | 177 x 102       | 3                | 3 | 3 | 3 |
| 5092D       | 16:9   | 92       | 203 x 114       | 209 x 120       | 3                | 3 | 3 | 3 |
| 50110D      | 16:9   | 110      | 244 x 137       | 252 x 145       | 4                | 4 | 4 | 4 |
| 50138D      | 16:9   | 138      | 305 x 172       | 313 x 180       | 4                | 4 | 4 | 4 |
| 5079D       | 16:10  | 79       | 171 x 107       | 177 x 113       | 3                | 3 | 3 | 3 |
| 5094D       | 16:10  | 94       | 203 x 127       | 209 x 133       | 3                | 3 | 3 | 3 |
| 50113D      | 16:10  | 113      | 244 x 153       | 252 x 161       | 4                | 4 | 4 | 4 |
| 50142D      | 16:10  | 142      | 305 x 191       | 313 x 199       | 4                | 4 | 4 | 4 |

## Optional Brackets

