

Installation Guide

MFT62

6 Input / 2 Output Multi-Format Switcher

4 HDMI, DisplayPort and VGA inputs with independent
HDMI and HDBaseT outputs

4K UHD

The MFT62 is a 4K 6-input to 2 output Mutli-Format Switcher and HDBaseT Transmitter that provides the following features:

- 4x HDMI inputs (4K UHD)
- 1x DisplayPort input
- 1x VGA input
- Local HDMI output
- Remote HDBaseT output
- 2x RS232 ports – For control and data pass through
- Bi-directional IR input/output
- External pushbutton interface
- EDID Management

The inputs can be independently selected for either of the outputs using the front panel buttons, RS232 commands, IR commands or external contact closures.

Front Panel

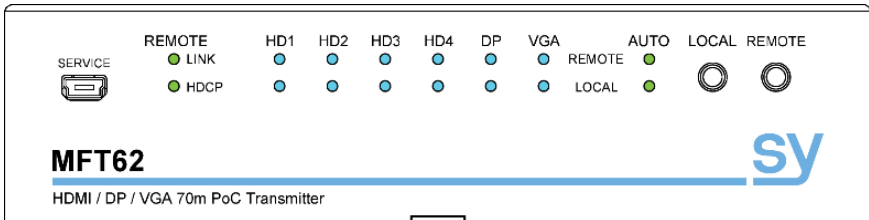

Name	Description
Service	Mini USB for firmware upgrades only
Remote Link	Indicates a link has been established with the remote receiver
Remote HDCP	Indicates the HDCP status for the remote receiver
HD1, HD2, HD3, HD4, DP and VGA	These blue LEDs indicate the current input selection for the Remote or Local outputs
Auto	These LEDs light up when the auto detection mode is active for either the Local or Remote outputs
Local button	Selects the input for the Local HDMI output
Remote button	Selects the input for the Remote HDBaseT output

Rear Panel

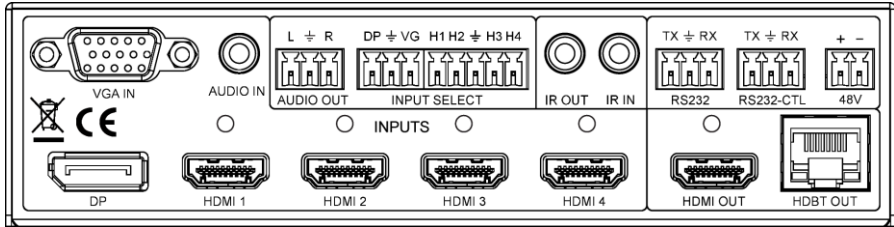

Name	Description
VGA IN	VGA input connector
Audio In	Analogue audio input for VGA IN
DP In	DisplayPort input connector
HDMI1 to HDMI4	HDMI Input connectors
HDMI Out	Local HDMI Output connector
HDBT Out	HDBaseT Output connector (PoC)
Audio Out	De-embedded analogue stereo audio output from HDBT OUT
Input Select	External pushbutton (push-to-make) interface for the Local Output
IR In	IR input from IR eye to control devices at the remote location
IR Out	IR output to control local devices from the remote location
RS232	Pass-through RS232 for HDBaseT output
RS232-CTL	RS232 for controlling the MFT62
48V	48V DC power input

Using the MFT62

1. Connect the video inputs as required.
2. Connect the video outputs as required.
3. Power up the MFT62.
4. Press the LOCAL button to select an input to the local display.
5. Press the REMOTE button to select an input to the remote display.
6. To use Auto input detection, press and hold either the LOCAL or the REMOTE buttons until its respective AUTO LED is lit. Auto Input detection is cancelled when the respective LOCAL or the REMOTE button is pressed and held until its AUTO LED has gone out.
7. An external pushbutton interface to the INPUT SELECT connector may also be used to select any input to the outputs either separately or simultaneously.

Front Panel Controls

The two front panel buttons allow for video input selection to the two outputs, enabling or disabling the auto input detection mode as well as changing the EDID setting for each input.

Local Button

The LOCAL button selects the signal source to send to the HDMI output of the MFT62. When the Local AUTO mode is off, repeated presses of the LOCAL button will switch sequentially through all the inputs, even if there is no signal present. When the Local AUTO mode is ON, only inputs with video signal present are selectable.

To enable or disable the Local AUTO mode, press and hold the LOCAL button until the LOCAL AUTO LED changes state (~ 3s).

Remote Button

The REMOTE button selects the signal source to send to the HDBaseT output of the MFT62. When the Remote AUTO mode is off, repeated presses of the REMOTE button will switch sequentially through all the inputs, even if there is no signal present. When the Local AUTO mode is ON, only inputs with video signal present are selectable.

To enable or disable the Local AUTO mode, press and hold the REMOTE button until the REMOTE AUTO LED changes state (~ 3s).

AUTO Detection Mode

With the Auto Mode enabled for either the LOCAL or REMOTE outputs, the MFT62 will only switch between inputs that have an active input signal. If a new input source is detected, the MFT62 will immediately switch to that input.

Should the currently selected input signal go off or become disconnected, then the MFT62 will automatically switch to the next available input signal. The direction in which this switching can be set using an RS232 command.

Input LED Modes

The Input LEDs provide visual feedback as to the selected input for both the LOCAL and REMOTE outputs. An OFF LED indicates input is not selected.

They also provide information about the input signal status as detailed in the following table:

Input Selection LED State	Input Signal State
ON	Selected - Input signal present / Active
Flashing	Selected - Input signal missing / Off
Off	Not Selected

De-embedded Audio output

The Remote HDBaseT output is de-embedded and presented on the phoenix L/R Stereo output. Only PCM stereo audio streams are extracted in this way.

Using an External Switches

The MFT62 has an interface for Input selection, using simple external Push Button switches, as shown in the following schematic:

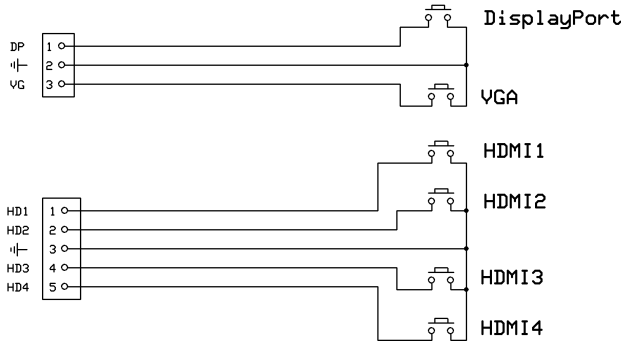

For each connector, pin 1 is left-most when viewed from the rear of the MFT62.

An LED can be used in parallel with each switch, mirroring the input selection status as per front panel (FP). Any input selection (from FP, external PB switches, RS232) is accordingly reflected on all FP LEDs, External PB switches/LEDs, and the RS232.

The output that is controlled by the external switch can be set using an RS232 command. The available settings are: Both outputs together; the Local output only or the Remote output only.

An additional feature provided by this external keypad is that an input can be selected for preview on the Local output before setting the Remote output to that same input by pressing the DP and VG buttons at the same time.

Cascade Mode

Cascade mode can be enabled/disabled via RS232 commands (SET CAD EN, SET CAD DIS), using RS232-CTL port. This may speed up the overall system switching speed when several devices are cascaded together (such as MFT62 to MSUHD88 to Apollo 4K to.....).

EDID Setting

Each of the 6 inputs can have its own comprehensive EDID management, using RS232 commands (RS232-CTL) or manually from the front panel.

Manual EDID Setting: To access this mode, press and hold both the Local & Remote buttons together (~3s) until the LEDs flash briefly.

Remote LEDs indicate the input being set. Use the Remote button to select the desired input.

Local LEDs show the EDID setting for the selected input. Use the Local button to change the EDID setting to another value.

Press and hold the Local button to accept the new setting. The MFT62 drops out of the manual EDID setting mode when a new setting is accepted or if there is no activity for about 10 seconds, at which time the MFT62 will revert to the previously stored settings.

The following EDID table applies only to the HD1, HD2, HD3, HD4 and DP inputs:

HD1	HD2	HD3	HD4	DP	VG	EDID Setting
<input type="radio"/>	<input type="radio"/>	<input type="radio"/>	<input type="radio"/>	<input type="radio"/>	<input type="radio"/>	1080P 2CH (PCM)
<input checked="" type="radio"/>	<input type="radio"/>	<input type="radio"/>	<input type="radio"/>	<input type="radio"/>	<input type="radio"/>	1080P 6CH
<input type="radio"/>	<input checked="" type="radio"/>	<input type="radio"/>	<input type="radio"/>	<input type="radio"/>	<input type="radio"/>	1080P 8CH
<input checked="" type="radio"/>	<input checked="" type="radio"/>	<input type="radio"/>	<input type="radio"/>	<input type="radio"/>	<input type="radio"/>	1080P 3D 2CH (PCM)
<input type="radio"/>	<input type="radio"/>	<input checked="" type="radio"/>	<input type="radio"/>	<input type="radio"/>	<input type="radio"/>	1080P 3D 6CH
<input checked="" type="radio"/>	<input type="radio"/>	<input checked="" type="radio"/>	<input type="radio"/>	<input type="radio"/>	<input type="radio"/>	1080P 3D 8CH
<input type="radio"/>	<input checked="" type="radio"/>	<input checked="" type="radio"/>	<input type="radio"/>	<input type="radio"/>	<input type="radio"/>	4K30Hz 3D 2CH (PCM)
<input checked="" type="radio"/>	<input checked="" type="radio"/>	<input checked="" type="radio"/>	<input type="radio"/>	<input type="radio"/>	<input type="radio"/>	4K30Hz 3D 6CH
<input type="radio"/>	<input type="radio"/>	<input type="radio"/>	<input checked="" type="radio"/>	<input type="radio"/>	<input type="radio"/>	4K30Hz 3D 8CH
<input checked="" type="radio"/>	<input type="radio"/>	<input type="radio"/>	<input checked="" type="radio"/>	<input type="radio"/>	<input type="radio"/>	4K60Hz (Y420) 3D 2CH (PCM)
<input type="radio"/>	<input checked="" type="radio"/>	<input type="radio"/>	<input checked="" type="radio"/>	<input type="radio"/>	<input type="radio"/>	4K60Hz (Y420) 3D 6CH
<input checked="" type="radio"/>	<input checked="" type="radio"/>	<input type="radio"/>	<input checked="" type="radio"/>	<input type="radio"/>	<input type="radio"/>	4K60Hz (Y420) 3D 8CH
<input type="radio"/>	<input type="radio"/>	<input checked="" type="radio"/>	<input checked="" type="radio"/>	<input type="radio"/>	<input type="radio"/>	1080P 2CH (PCM) HDR
<input checked="" type="radio"/>	<input type="radio"/>	<input checked="" type="radio"/>	<input checked="" type="radio"/>	<input type="radio"/>	<input type="radio"/>	1080P 6CH HDR
<input type="radio"/>	<input checked="" type="radio"/>	<input checked="" type="radio"/>	<input checked="" type="radio"/>	<input type="radio"/>	<input type="radio"/>	1080P 8CH HDR
<input checked="" type="radio"/>	<input checked="" type="radio"/>	<input checked="" type="radio"/>	<input checked="" type="radio"/>	<input type="radio"/>	<input type="radio"/>	1080P 3D 2CH (PCM) HDR
<input type="radio"/>	<input type="radio"/>	<input type="radio"/>	<input type="radio"/>	<input checked="" type="radio"/>	<input type="radio"/>	1080P 3D 6CH HDR
<input checked="" type="radio"/>	<input type="radio"/>	<input type="radio"/>	<input type="radio"/>	<input checked="" type="radio"/>	<input type="radio"/>	1080P 3D 8CH HDR
<input type="radio"/>	<input checked="" type="radio"/>	<input type="radio"/>	<input type="radio"/>	<input checked="" type="radio"/>	<input type="radio"/>	4K30Hz 3D 2CH (PCM) HDR
<input checked="" type="radio"/>	<input checked="" type="radio"/>	<input type="radio"/>	<input type="radio"/>	<input checked="" type="radio"/>	<input type="radio"/>	4K30Hz 3D 6CH HDR
<input type="radio"/>	<input type="radio"/>	<input checked="" type="radio"/>	<input type="radio"/>	<input checked="" type="radio"/>	<input type="radio"/>	4K30Hz 3D 8CH HDR
<input checked="" type="radio"/>	<input type="radio"/>	<input checked="" type="radio"/>	<input type="radio"/>	<input checked="" type="radio"/>	<input type="radio"/>	4K60Hz (Y420) 3D 2CH (PCM) HDR
<input type="radio"/>	<input checked="" type="radio"/>	<input checked="" type="radio"/>	<input type="radio"/>	<input checked="" type="radio"/>	<input type="radio"/>	4K60Hz (Y420) 3D 6CH HDR
<input checked="" type="radio"/>	<input checked="" type="radio"/>	<input checked="" type="radio"/>	<input type="radio"/>	<input checked="" type="radio"/>	<input type="radio"/>	4K60Hz (Y420) 3D 8CH HDR
<input type="radio"/>	<input type="radio"/>	<input type="radio"/>	<input checked="" type="radio"/>	<input checked="" type="radio"/>	<input type="radio"/>	USER1 EDID
<input checked="" type="radio"/>	<input type="radio"/>	<input type="radio"/>	<input checked="" type="radio"/>	<input checked="" type="radio"/>	<input type="radio"/>	USER2 EDID
<input type="radio"/>	<input checked="" type="radio"/>	<input type="radio"/>	<input checked="" type="radio"/>	<input checked="" type="radio"/>	<input type="radio"/>	USER3 EDID

The following EDID table applies only to the VGA input:

HD1	HD2	HD3	HD4	DP	VG	EDID Setting
<input type="radio"/>	<input type="radio"/>	<input type="radio"/>	<input type="radio"/>	<input type="radio"/>	<input type="radio"/>	VGA 1080P
<input checked="" type="radio"/>	<input type="radio"/>	<input type="radio"/>	<input type="radio"/>	<input type="radio"/>	<input type="radio"/>	USER1 EDID
<input type="radio"/>	<input checked="" type="radio"/>	<input type="radio"/>	<input type="radio"/>	<input type="radio"/>	<input type="radio"/>	USER2 EDID
<input checked="" type="radio"/>	<input checked="" type="radio"/>	<input type="radio"/>	<input type="radio"/>	<input type="radio"/>	<input type="radio"/>	USER3 EDID

The USER1 EDID, USER2 EDID and USER3 EDID memory locations on each input can only be programmed by using RS232 commands, and must contain valid EDID data before being used.

Connecting the MFT62

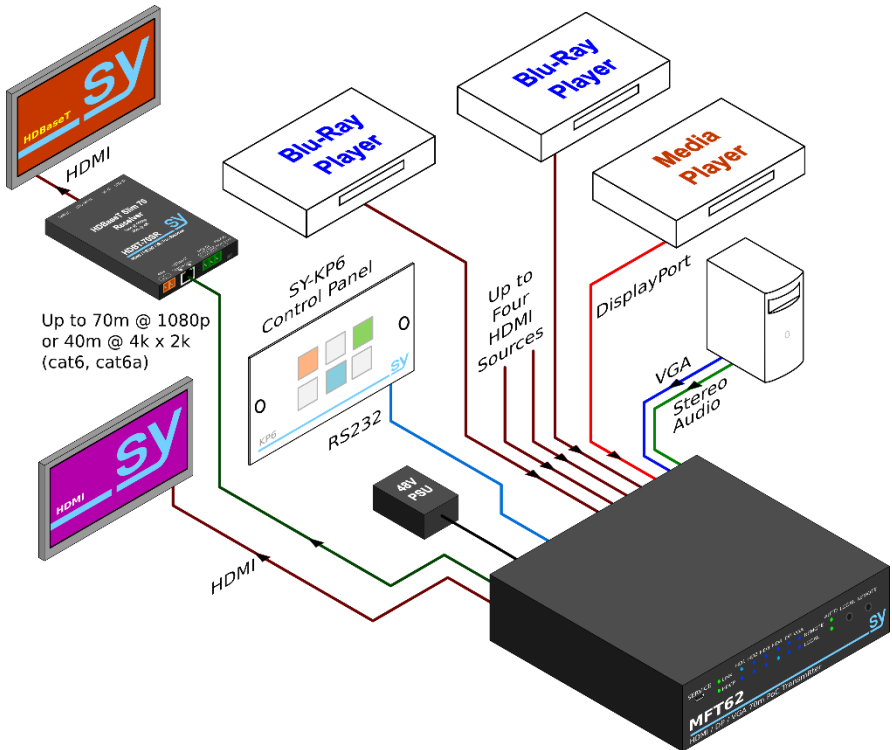

RS232-CTL Commands

All commands are sent at 57600 baud, 8 data bits, no parity and one stop bit.

Commands are not case sensitive, but must always be followed by a carriage-return (0x0d). All spaces are optional, but are shown in the command tables for clarification.

All response messages are in uppercase and provide an acknowledgement of the command or reply with the requested data. All responses are terminated with a carriage-return & line-feed sequence (0x0d 0x0a).

System Commands

H	Help – list all available commands
STA	Show Global System Status
SET RST	Reset to Factory Defaults
SET ADDR xx	Set System Address to xx, where xx is in the range [00~99]. The factory default is 00
GET ADDR	Get System Address
SET CAS DIS	Turn Cascade mode OFF for both outputs
SET CAS EN	Turn Cascade mode ON for both outputs
GET CAS	Get Cascade Mode Status
GET STA	Get System Status

Output Setup Commands

SET OUTx VS INy	<p>Set Output x To Input y</p> <p>Output x is:</p> <ul style="list-style-type: none"> 0 = Both outputs (HDMI & HDBaseT) 1 = Local HDMI output 2 = Remote HDBaseT output <p>Input y is:</p> <ul style="list-style-type: none"> 1-4 = HDMI inputs 1 to 4 5 = DisplayPort input 6 = VGA input
SET OUT EXA DIS	Disable Extracted Audio Output
SET OUT EXA EN	Enable Extracted Audio Output
GET OUTx VS	<p>Get Output x Video Routing</p> <p>Output x is:</p> <ul style="list-style-type: none"> 0 = Both outputs (HDMI & HDBaseT) 1 = Local HDMI output 2 = Remote HDBaseT output
GET OUT EXA	Get Ex-Audio Output Enable/Disable Status

Back Panel PB Input Selection

SET BP SEL BUTx	Set "INPUT SELECT" Push buttons to operate output x is: 0 = Both outputs, 1 = Local HDMI, 2 = Remote HDBT
GET BP SEL BUT	Get "INPUT SELECT" push buttons function setting

Input EDID Setup Commands

<p>SET INx EDID y</p>	<p>Set Input x EDID to the built-in EDID y Input y is</p> <ul style="list-style-type: none"> 1- 4 = HDMI inputs 1 to 4 5 = DisplayPort input <p>EDID y is one of the following (0-26):</p> <ul style="list-style-type: none"> 0: 1080P_2CH(PCM) 1: 1080P_6CH 2: 1080P_8CH 3: 1080P_3D_2CH(PCM) 4: 1080P_3D_6CH 5: 1080P_3D_8CH 6: 4K30Hz_3D_2CH(PCM) 7: 4K30Hz_3D_6CH 8: 4K30Hz_3D_8CH 9: 4K60Hz(Y420)_3D_2CH(PCM) 10: 4K60Hz(Y420)_3D_6CH 11: 4K60Hz(Y420)_3D_8CH 12: 1080P_2CH(PCM)_HDR 13: 1080P_6CH_HDR 14: 1080P_8CH_HDR 15: 1080P_3D_2CH(PCM)_HDR 16: 1080P_3D_6CH_HDR 17: 1080P_3D_8CH_HDR 18: 4K30Hz_3D_2CH(PCM)_HDR 19: 4K30Hz_3D_6CH_HDR 20: 4K30Hz_3D_8CH_HDR 21: 4K60Hz(Y420)_3D_2CH(PCM)_HDR 22: 4K60Hz(Y420)_3D_6CH_HDR 23: 4K60Hz(Y420)_3D_8CH_HDR 24: USER1_EDID 25: USER2_EDID 26: USER3_EDID
<p>SET IN6 EDID y</p>	<p>Set Input 6 (VGA) EDID where y is in the range 0~3.</p> <p>Where y is:</p> <ul style="list-style-type: none"> 0 = VGA1080P 1 = USER1_EDID 2 = USER2_EDID 3 = USER3_EDID
<p>SET INx EDID CY OUTy</p>	<p>Copy Output y EDID To Input x(USER1 BUF) {x[1~6], y[1~2]}</p> <p>Input x is:</p> <ul style="list-style-type: none"> 1-4 = HDMI inputs 1 to 4 5 = DisplayPort input 6 = VGA input <p>Output y is:</p> <ul style="list-style-type: none"> 1 = Local HDMI output 2 = Remote HDBaseT output

SET IN _x EDID U _y DATA _z	Write EDID To User <i>y</i> Buffer of Input <i>x</i> { <i>x</i> [1~6], <i>y</i> [1~3], <i>z</i> [EDID Data]}
GET IN _x EDID	Get Input <i>x</i> EDID Index { <i>x</i> [0~6]{0All}}
GET IN _x EDID <i>y</i> DATA	Get Input <i>x</i> EDID <i>y</i> Data { <i>x</i> [1~5], <i>y</i> [0~26]}
GET IN ₆ EDID <i>y</i> DATA	Get VGA input EDID <i>y</i> Data { <i>y</i> [0~3]}
GET OUT _x EDID DATA	Get Output <i>x</i> EDID Data x is: 1 = Local HDMI output, 2 = Remote HDBaseT output

IR Code Setup

SET IR SYS <i>xx yy</i>	Set IR System Code Where <i>xx</i> and <i>yy</i> define a 16-bit address, each in the range [00-FF] (Factory default is 00 FF)																					
SET IR OUT _x IN _y CODE <i>zz</i>	Set IR Data Code { <i>x</i> [1~2], <i>y</i> [1~6], <i>zz</i> {00~FF}} Define the IR data code to select the inputs and outputs: Output <i>x</i> is: 1 = Local HDMI output 2 = Remote HDBaseT output Input <i>y</i> is: 1 - 4 = HDMI inputs 1 to 4 5 = DisplayPort input 6 = VGA input Data value <i>zz</i> is for the given input and output combination. Each value must be unique. Default IR values are: <table style="margin-left: 40px; border: none;"> <thead> <tr> <th></th> <th>Local</th> <th>Remote</th> </tr> </thead> <tbody> <tr> <td>HDMI 1 to Output</td> <td>0x80</td> <td>0x90</td> </tr> <tr> <td>HDMI 2 to Output</td> <td>0x82</td> <td>0x92</td> </tr> <tr> <td>HDMI 3 to Output</td> <td>0x84</td> <td>0x94</td> </tr> <tr> <td>HDMI 4 to Output</td> <td>0x86</td> <td>0x96</td> </tr> <tr> <td>DisplayPort to Output</td> <td>0x88</td> <td>0x98</td> </tr> <tr> <td>VGA to Output</td> <td>0x8a</td> <td>0x9a</td> </tr> </tbody> </table>		Local	Remote	HDMI 1 to Output	0x80	0x90	HDMI 2 to Output	0x82	0x92	HDMI 3 to Output	0x84	0x94	HDMI 4 to Output	0x86	0x96	DisplayPort to Output	0x88	0x98	VGA to Output	0x8a	0x9a
	Local	Remote																				
HDMI 1 to Output	0x80	0x90																				
HDMI 2 to Output	0x82	0x92																				
HDMI 3 to Output	0x84	0x94																				
HDMI 4 to Output	0x86	0x96																				
DisplayPort to Output	0x88	0x98																				
VGA to Output	0x8a	0x9a																				
GET IR SYS	Get IR System Code																					
GET IR OUT _x IN _y CODE	Get IR Data Code for { <i>x</i> [0~2], <i>y</i> [1~6]} <i>x</i> [0~2] 0 = Both outputs, 1 = Local HDMI, 2 = Remote HDBaseT <i>y</i> [1~6] 1 - 4 = inputs HDMI 1 to 4, 5 = DP, 6 = VGA																					

Auto Mode Commands

SET HD _x AUTO EN	Enable Auto Mode. x is: 0=Both, 1= Local HDMI, 2= Remote HDBT
SET HD _x AUTO DIS	Disable Auto Mode. x is: 0=Both, 1= Local HDMI, 2= Remote HDBT
SET HD _x ACRCN	Switch to the next available input port, for output <i>x</i> x is: 0 = Both outputs, 1 = Local HDMI, 2 = Remote HDBT
SET AUTO DETECT L	Auto mode fall back to the LEFT (6, 5, 4,)
SET AUTO DETECT R	Auto mode fall back to the RIGHT (1, 2, 3,)
GET HD _x AUTO	Get output Auto mode status. x is: 1 = Local HDMI, 2= Remote HDBT
GET AUTO DETECT	Get Auto Mode direction status

Other Response Messages

There are two additional response messages that indicate the input signal status:

INx SIG STA 1	A valid signal is detected at input x. x = 0 - 6
INx SIG STA 0	The signal for input x is turned off or disconnected. x = 0 - 6

The above messages are sent either when the MFT62 is powered up or whenever the status of the input signal changes. They are not included as part of the GET STA or STA commands.

The input signal status can be obtained using the STA command, which provides a detailed report of the status and settings of the MFT62.

Specification

Items	Description
HDMI Video Input/output	VESA and SMPTE 480p to 2160p (4K UHD) with 3D. (All resolutions to: 4096x2160p @60Hz 4:2:0 8bit, 3840x2160p @30Hz 4:4:4 8bit) All PC resolutions to 1920x1200
VGA Video Input	The following VGA resolutions are supported: 800x600, 1024x768, 1280x768, 1280x800, 1280x1024, 1400x1050, 1600x1200, 1920x1080 and 1920x1200.
HDMI Audio Input/output	Pass through: All HDMI audio formats including Dolby D (TrueHD) / DTS (HD-Master Audio) / PCM. Channel count: from 2-8 (2.0 to 7.1) Sample rates: 32 kHz, 44.1 kHz, 48 kHz, 88.2 kHz, 96 kHz, 176.4 kHz and 192 kHz
De-embedded Audio out	PCM 2.0 channel from HDBT output, onto 3 pin Phoenix connector. Stereo L/R, 0.7V Rms – 20Hz-20KHz
Power Supply	48V DC @ 0.5A max.
Power Consumption	14.4W including the receiver
HDBaseT Output	Max 70m (230feet) of cat6a, @ 1080p. HDMI video, RS232, IR control, PoC PoC is available only when SY-HDBT-SLIM-70SR is detected on the HDBT output.
Control	RS232 & IR Full function bi-directional pass-through RS232-CTL port – 57,600 Baud, no Parity, 1 Stop bit
Dimensions	164 x 145 x 40mm
Case Material	Aluminium chassis
Weight	860g

De-embedded Audio output

The Remote HDBaseT output is de-embedded and presented on the phoenix L/R Stereo output. Only PCM stereo audio streams are extracted in this way.

Note: You may use cat5e, cat6 UTP in conjunction with the HDBaseT output; however for best performance use cat6a or cat7 (particularly in electrically noisy environments). The maximum distances & transmission performance for HDMI and HDBT may be compromised by cable quality, patch panels, poor termination, wall plates, cable kinks and electrical interferences. Generally ensure the cat cable is solid copper core (avoid CCA type), in one straight run (avoid/minimise patches) and avoid close proximity to any noisy electrical sources.

Safety Instructions

To ensure reliable operation of this product as well as protecting the safety of any person using or handling these devices while powered, please observe the following instructions.

1. Use the power supplies provided. If an alternate supply is required, check Voltage, polarity and that it has sufficient power to supply the device it is connected to.
2. Do not operate either of these products outside the specified temperature and humidity range given in the above specifications.
3. Ensure there is adequate ventilation to allow this product to operate efficiently.
4. Repair of this equipment should only be carried out by qualified professionals as this product contains sensitive devices that may be damaged by any mistreatment.
5. Only use this product in a dry environment. Do not allow any liquids or harmful chemicals to come into contact with this product.

After Sales Service

1. Should you experience any problems while using this product, firstly refer to the Troubleshooting section in this manual before contacting SY Technical Support.
2. When calling SY Technical Support, the following information should be provided:
 - Product name and model number
 - Product serial number
 - Details of the fault and any conditions under which the fault occurs.
3. This product has a two year standard warranty, beginning from the date of purchase as stated on the sales invoice. For full details please refer to our Terms and Conditions.
4. SY Product warranty is automatically void under any of the following conditions:
 - The product is already outside of its warranty period
 - Damage to the product due to incorrect usage or storage
 - Damage caused by unauthorised repairs
 - Damage caused by mistreatment of the product
5. Please direct any questions or problems you may have to your local dealer before contacting SY Electronics.